

GE

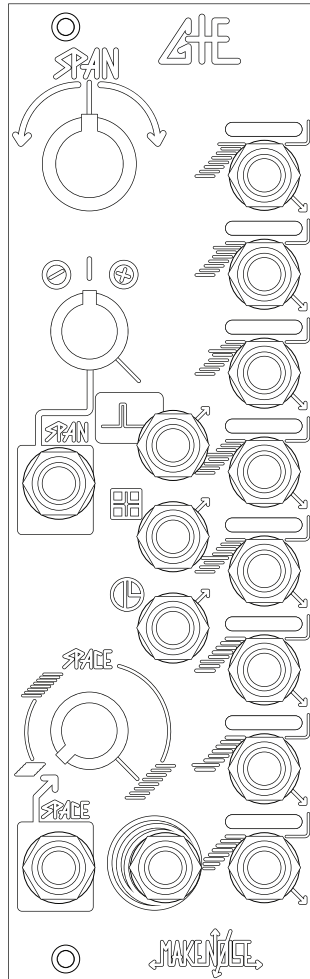

← MAKE NOISE →

TABLE OF CONTENTS

- LIMITED WARRANTY
- INSTALLATION
- INTRODUCTION
- PANEL CONTROLS
- GTE EXPLAINED



LIMITED WARRANTY

Make Noise warrants this product to be free of defects in materials or construction for a period of one year from the date of purchase (proof of purchase/invoice required).

Malfunction resulting from wrong power supply voltages, backwards or reversed eurorack bus board cable connection, abuse of the product, removing knobs, changing faceplates, or any other causes determined by Make Noise to be the fault of the user are not covered by this warranty, and normal service rates will apply.

During the warranty period, any defective products will be repaired or replaced, at the option of Make Noise, on a return-to-Make Noise basis with the customer paying the transit cost to Make Noise.

Make Noise implies and accepts no responsibility for harm to person or apparatus caused through operation of this product.

Please contact technical@makenoisemusic.com with any questions, Return To Manufacturer Authorization, or any needs & comments.

<http://www.makenoisemusic.com>



About This Manual:

Written by Tony Rolando and Walker Farrell
Illustration and layout by Lewis Dahm



INSTALLATION

Electrocution hazard!

Always turn the Eurorack case off and unplug the power cord before plugging or unplugging any Eurorack bus board connection cable. Do not touch any electrical terminals when attaching any Eurorack bus board cable.

The Make Noise GTE is an electronic music module requiring 25mA of +12VDC and 2mA of -12VDC regulated voltage and a properly formatted distribution receptacle to operate. It must be properly installed into a Eurorack format modular synthesizer system case.

Go to <http://www.makenoisemusic.com/> for examples of Eurorack Systems and Cases.

To install, find 8HP in your Eurorack synthesizer case, confirm proper installation of Eurorack bus board connector cable on backside of module (see picture below), plug the bus board connector cable into the Eurorack style bus board, minding the polarity so that the RED stripe on the cable is oriented to the NEGATIVE 12 Volt line on both the module and the bus board. On the Make Noise 6U or 3U Busboard, the negative 12 Volt line is indicated by the white stripe.

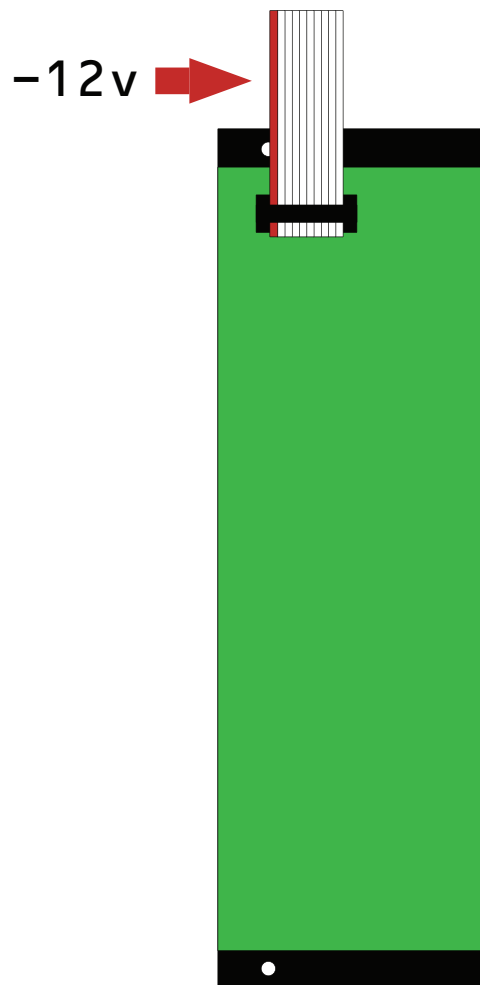

Please refer to your case manufacturer's specification for location of the negative supply.



OVERVIEW

The **Gestural Time Extractor (GTE)** music synthesizer module is an analog pulse extractor and Channel Index Translator for the New Universal Synthesizer System or any Eurorack modular system.

From the motion of the signal at the Span input, it derives up to eight individual channel pulses, as well as a GTE pulse stream representing the speed of motion of the input signal, and two gate outputs representing activity at the even and odd channels.

The Space parameter determines the threshold proximity of the channels to each other and thereby also the sensitivity and reactivity of the GTE and other outputs.

When the Trigger input is in use, the GTE's output channel will only change upon reception of a trigger or gate, allowing for changes to easily be synchronized with other existing events in the system.

With all controls set to starter min-max positions, the GTE also operates as a Channel Index Translator for PoliMATHS and other New Universal Synthesizer System modules that generate Channel Index signals, allowing the accurate derivation of individual channel gates from activity at the respective channels of the source module.

The GTE can be used to generate repeatable and controllable rhythm and timing information from any analog synthesizer signal, whether arbitrary or targeted, and is also useful for individual voice timing signal generation within a multi-voice N.U.S.S. system.

- Extract rhythms, clocks and pulse streams from any control voltage source
- Opens up the patch programmability of the N.U.S.S.
- Synchronize GTE to any clock source with the Trigger input
- Use GTE to synchronize any event in your system with Activations from PoliMATHS and MultiWAVE - regardless of Span mode
- Compact and powerful analog module
- Pairs well with MATHS, PoliMATHS or Jumbler



PANEL CONTROLS

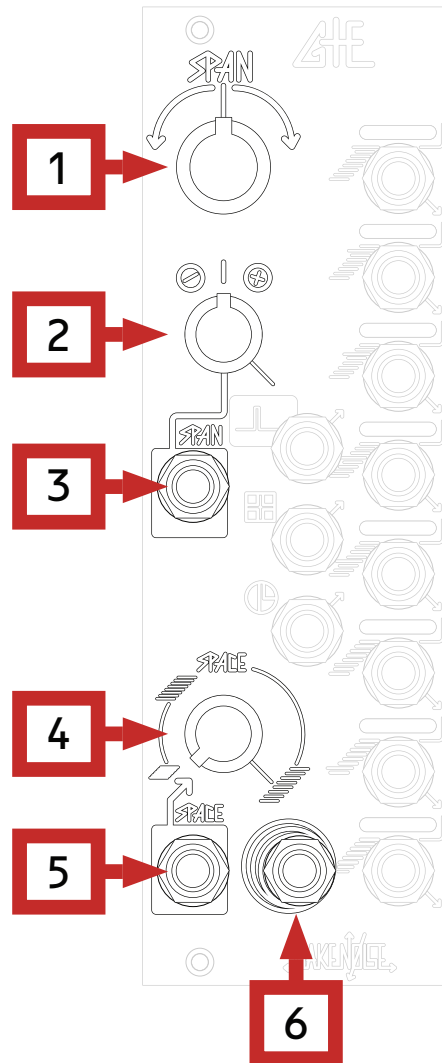

1. Span Panel Control
2. Span Attenuverter
3. Span CV In
4. Space Panel Control
5. Space CV In
6. Trigger In



PANEL CONTROLS

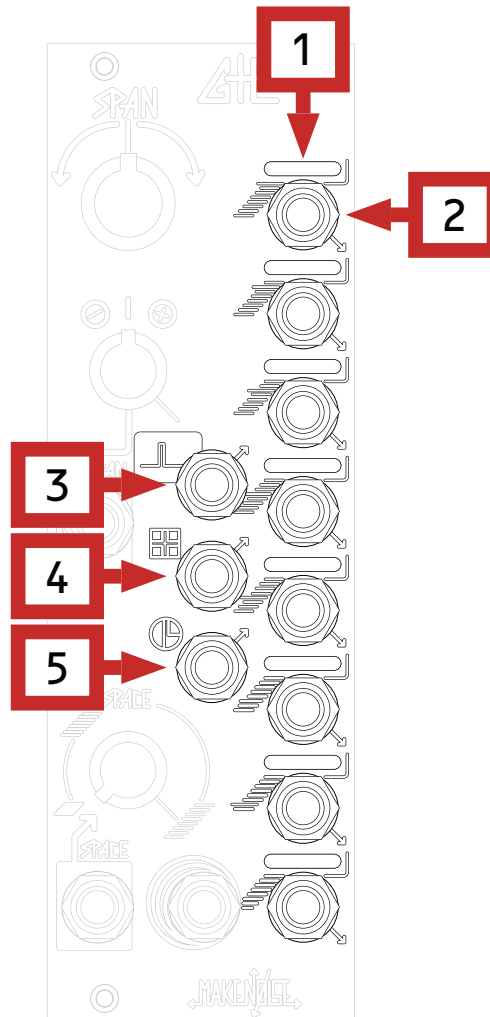

1. Channel LED
2. Channel Out
3. Pulse Stream Out
4. Even Out
5. Odd Out



GTE EXPLAINED

Span

CV input for selection of channel for extracting gates from any CV gesture. As voltage increases, so does channel selection. Sensitivity set by Space parameter.

Space

Sets the range of input voltage that will be necessary for Span to reach all eight channels. As this parameter decreases, smaller changes at Span will result in greater channel Spans and thereby denser activity at the outputs. When Space reaches its minimum, the total Span voltage becomes infinitesimally small.

Channel Outputs

Eight gate outputs representing eight possible values of the Span control. At any given time one output is high, unless Span goes higher or lower than the full range of outputs as determined by Space.

Odd/Even Outputs

Outputs representing Odd (1, 3, 5, 7) and Even (2, 4, 6, 8) channels. If any channel is currently active then exactly one of these outputs will also be active, depending on whether the channel is Even or Odd.

GTE Output

Trigger output that fires a short pulse any time a new Channel is selected via Span.

Clock Input

When in use, the GTE's output channel will only change upon the rising edge of a gate or trigger, allowing for changes to easily be synchronized with other existing events in the system.

Channel Index Translation

With Span panel control set fully counterclockwise, and Span input attenuverter and Space panel control set fully clockwise, patch a Channel Index signal from PoliMATHS or other New Universal Synthesizer System module to generate eight gate outputs that coincide precisely with channel activity at the source module.

When multiple channels are Activated at once at the source module, each Activated channel's index is generated successively as a rapid series of 5ms triggers, ending with the final channel staying high as normal. This technique of analog data transmission is called FDD (Flam Data Delivery) and results in a quick downward Flam of gates at the GTE channel outputs.

